



# TYKT404DA RANGE

Emergency LED Downlighter

**Product:** TYKT404DA

**Description:** Recessed ceiling mounted emergency LED downlighter. 3 Hour, non-maintained.

- Standards:**
- EN60598-1
  - EN60598-2-22
  - EN55015
  - EN61547
  - EN61000-3-2
  - CE marked

**Specification:**

Total Weight: 250 g.

Mounting Position: Recessed ceiling.

Lamps: 2 x Luxeon Rebel ES LED.

Supply Voltage: 220-240V DC/AC 50/60Hz.

Supply Current: <100mA (during normal luminaire operation, after inrush on start-up).

DALI: Dedicated DALI interface for customer controlled monitoring & reporting.  
Also, stand-alone automatic testing in accordance with IEC62034 if not connected to a DALI system.

Operating Temp: Min 0°C / Max 25°C.

IP Rating: IP20.

Luminous Flux: 280 lm.

Ceiling Cut-Out: 43mm diameter as standard for false ceilings.

For complete installation from below the ceiling, a 55mm diameter cut-out and a minimum void depth of 160mm is required (based on 12mm thick ceiling material). Also, a TYKTRDLB extender bezel must be used to cover the 55mm diameter cut-out (please order bezel separately).

Please allow for at least 50mm air gap either side of the gear housing.

Finish: White Bezel Only.

**Dimensions:**

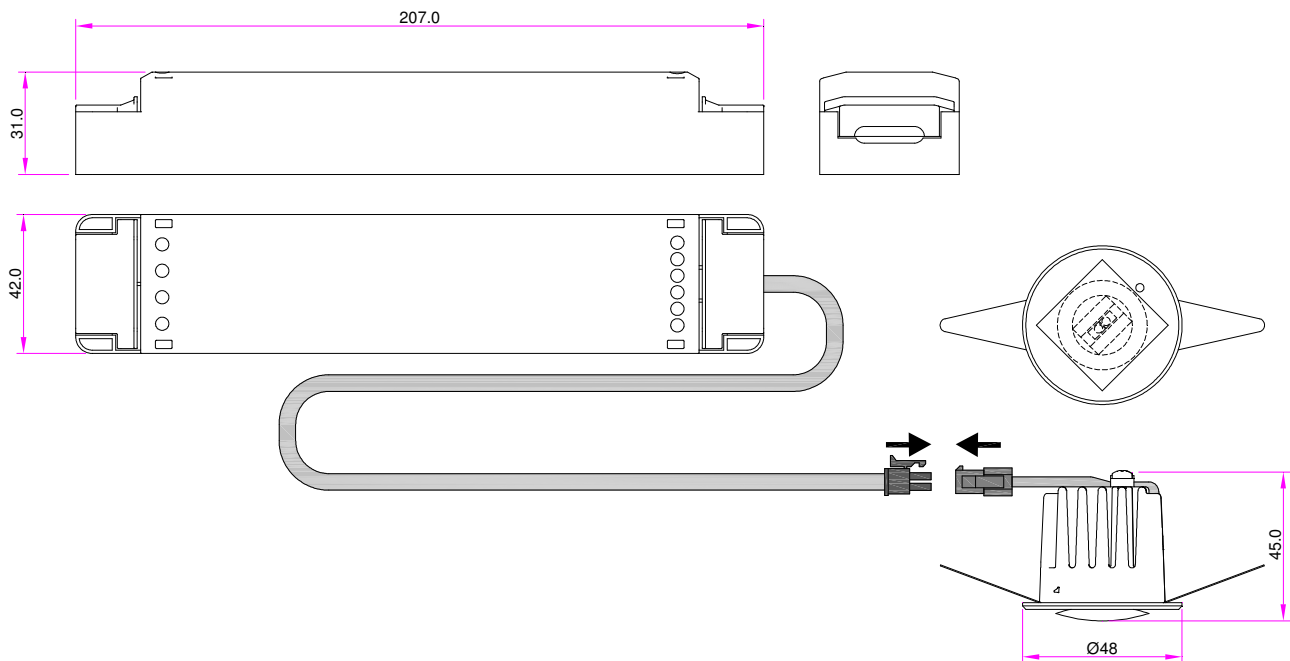

## Luminaire Spacing's

Ceiling Height					
<b>NFPA 101 Escape Routes 0.71m Wide</b>					
<b>2.5m</b>	2.5m	5.4m	6.3m	6.8m	3.2m
<b>3.0m</b>	1.6m	4.4m	5.6m	6.8m	3.0m
<b>3.5m</b>	0.7m	3.8m	4.8m	5.8m	1.7m
<b>4.0m</b>	-	2.8m	3.8m	4.8m	-
<b>BS5266-1:2011 Escape Routes 2m Wide</b>					
<b>2.5m</b>	3.1m	6.6m	6.7m	6.9m	3.3m
<b>3.0m</b>	3.5m	7.6m	7.8m	8.0m	3.7m
<b>3.5m</b>	3.9m	8.6m	8.8m	9.1m	4.2m
<b>4.0m</b>	4.2m	9.4m	9.7m	10m	4.5m
<b>BS5266-1:2011 Open Areas</b>					
<b>2.5m</b>	2.9m	5.6m	5.6m	5.6m	2.9m
<b>3.0m</b>	3.3m	6.6m	6.6m	6.6m	3.3m
<b>3.5m</b>	3.6m	7.4m	7.4m	7.4m	3.6m
<b>4.0m</b>	3.9m	8.1m	8.1m	8.1m	3.9m

The spacing table is based on a 0.80 Maintenance factor.

## Philip Payne Ltd

A SUBSIDIARY OF F.W. THORPE PLC  
Thornhill Road, Lode Lane, Solihull, B91 2HB, England.

Tel: 0121 705 2384

Fax: 0121 711 2469

e-mail: [mail@philippayne.co.uk](mailto:mail@philippayne.co.uk)

Website: <http://www.philippayne.co.uk>

Philip Payne Ltd registered in England No. 1361523



ISO 9001  
FM55077

TYKT404DA\_5